

*Hydraulic
press brakes*

PPEB SERIES

CONFIGURED TO YOUR NEEDS

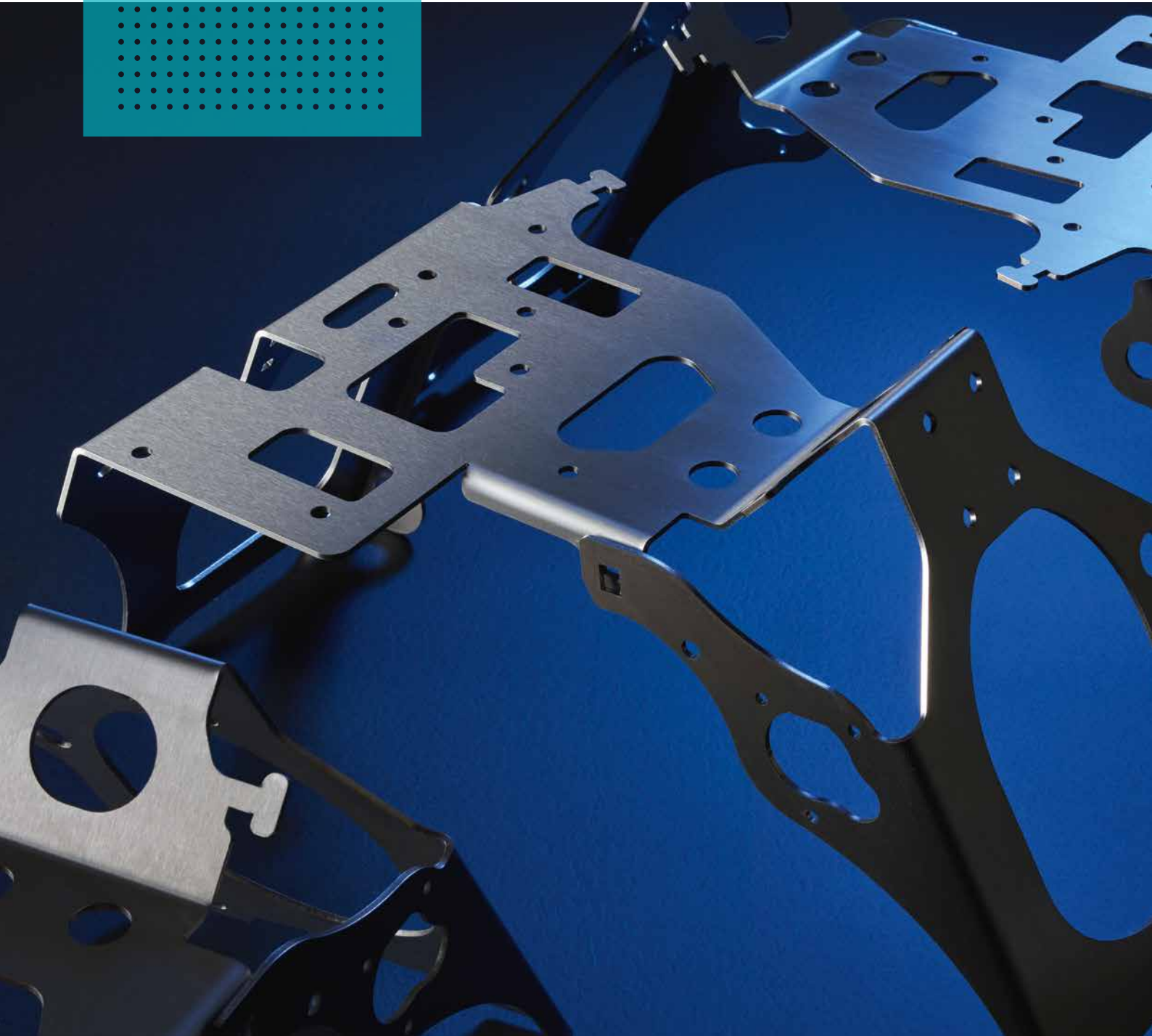

PPEB SERIES

CONFIGURED TO YOUR NEEDS

PPEB press brakes offer precision bending in a flexible design. You configure a PPEB to suit your requirements – choose your backgauge, increase the distance between table and ram, integrate a robot interface, horn extensions or CNC sheet supports. The options are numerous. Whether your application is simple or complex, a PPEB is designed to specifically address your production needs in a press brake that is proven accurate and reliable.



USER-FRIENDLY TOUCH SCREEN CONTROL

The 19" Touch-B control is intuitive and easy-to-use.

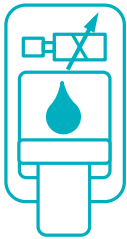

ACCURATE HYDRAULIC SYSTEM

Manufactured in-house by LVD, the servo-controlled hydraulic system delivers power efficiency and high accuracy in a field-proven design.



ROBUST FRAME

PPEB models up to 400 ton/4m have a one-piece welded frame that can be installed at floor level. Longer bed lengths and higher pressing forces may require modified floor arrangements.





TAILOR-MADE

Numerous options ensure that your PPEB completely matches your application requirements: increased distance table-ram, wider table, hydraulic clamping, and many more.



STATUS LIGHTING

LED lights indicate the machine status.

AUTOMATIC CROWNING



Standard on PPEB-5 and PPEB-8 models, the crowning system ensures parallel bending every time.

LINEAR ENCODERS

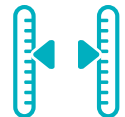

Referenced encoders are connected to the bed in such a way that deformation during bending does not influence the positioning accuracy of the ram.



BACKGAUGE SYSTEM

The 2-, 5- or 6-axis backgauge is automatically positioned for optimum bending results.

CNC CROWNING

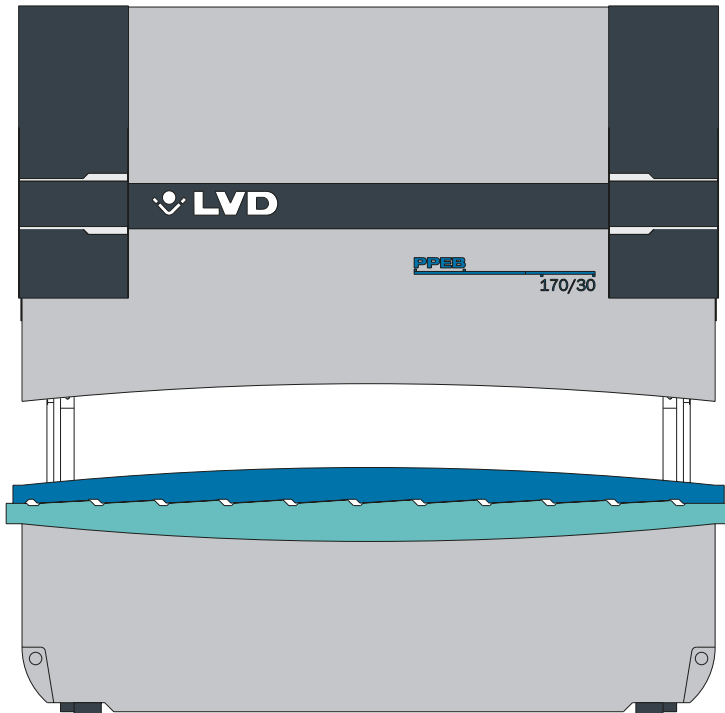
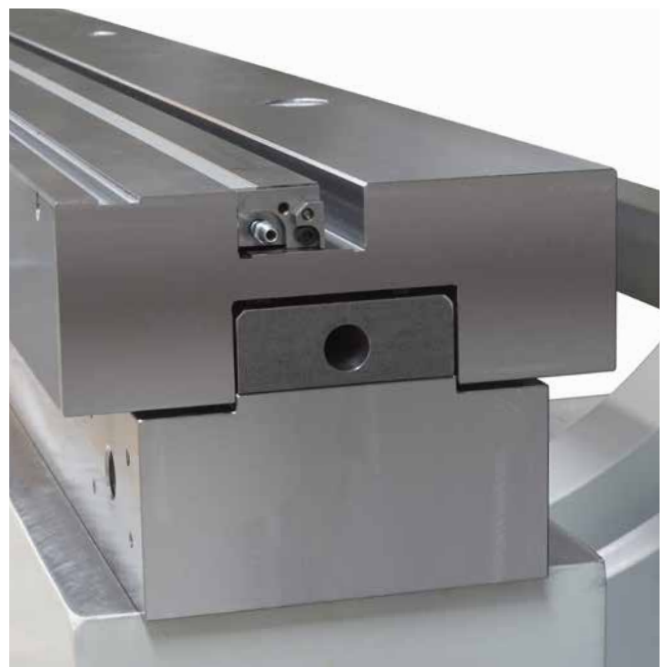
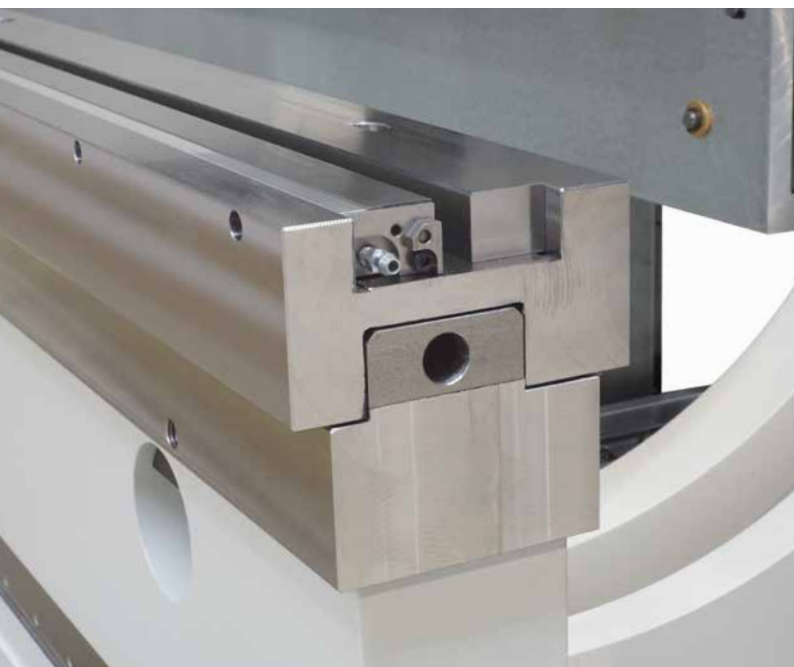

Fig. b

The servo-hydraulic system ensures that the piston at each end of the ram reaches the programmed position established in the Touch-B control. This assures a correct bend angle under the piston.

Press brakes have a natural tendency to deflect under load, particularly in the centre between the pistons. As a result, without intervention, the bend angle will vary over the length of the press brake. To compensate for this problem, PPEB press brakes are equipped with a tailor-made crowning device which consists of two rows of wedges. The crowning device is controlled through the Touch-B control and compensates for the bed deflection and the ram under different bending forces.

The crowning device is tailor-made for each individual machine. The associated components are machined and finished following the geometrical measurement between the ram and lower frame.



FLEXIBLE BACKGAUGE SYSTEM

A solidly constructed, two-axis backgauge allows precise depth (X-axis) and height (R-axis) positioning of the two standard back gauge fingers. PPEB-8 models offer the additional flexibility of Z1 and Z2 motorised backgauge movement.

The standard PPEB backgauge fingers allow gauging to 1000 mm and also serve as material supports. PPEB-4 and PPEB-5 can be equipped with an additional third finger, ideally suited to the bending of omega and other similar profiles.

	PPEB-4	PPEB-5	PPEB-8
X-R	X	X	
X-R-Z1-Z2-X'			X

Standard two-axis backgauge (X, R) with manual Z-axis on PPEB-4 and PPEB-5



Optional modular backgauge (X1, R1, Z1 - X2, R2, Z2) up to 400 T on PPEB-8



Five-axis backgauge (X, R, Z1, Z2, X') on PPEB-8

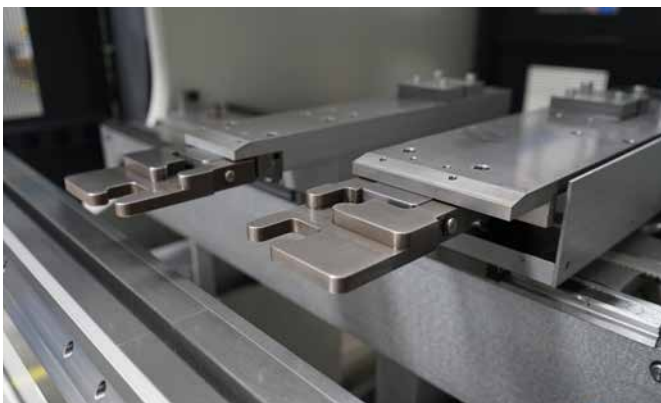

Modular backgauge (X1, R1, Z1 - X2, R2, Z2) for 500 T and 640 T on PPEB-8

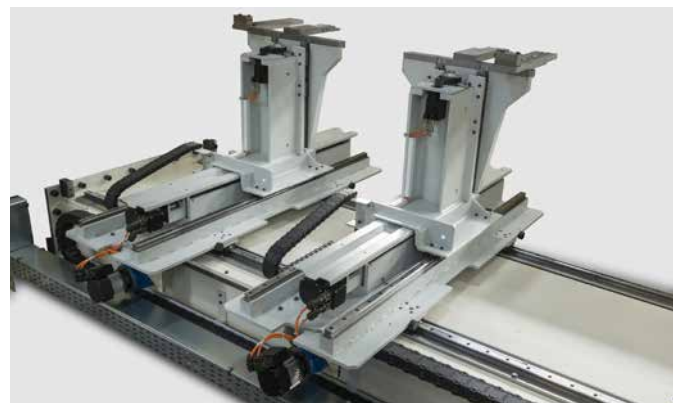

WIDE RANGE OF CAPACITIES



PPEB 80/15



PPEB 135/30





TANDEM

PPEB 320/51



A 100 WAYS TO CONFIGURE YOUR PRESS BRAKE

There are numerous ways to configure a PPEB according to your needs. Select the stroke and table-ram distance. Choose a wider table for multi-V dies or quick-acting hydraulic clamping on the table. Add an interface for a robot

connection, turbo technology, barcode scanner, oil cooler with air or air conditioner for the electrical cabinet. You can even designate a special color, add a second remote console, and more.

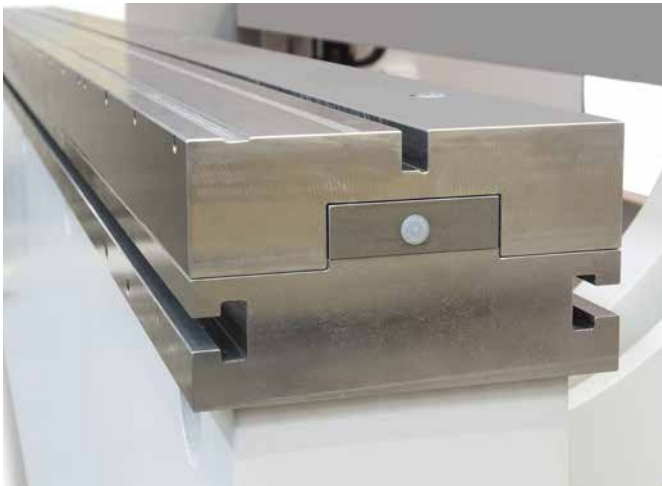

Wider table for use of multi-V dies



Front supports on guide rails allow quick positioning along the entire bending length



Two programmable sheet followers



Extended parking zone left/right.

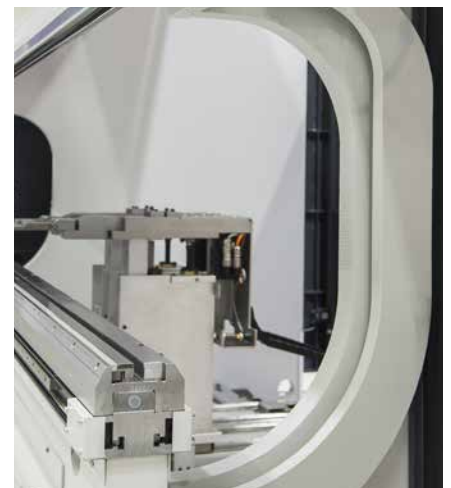

Increased table-ram/stroke/gap distance in 100 mm steps



Quick acting hydraulic clamping on ram and on table



LED lights on front and back side



Additional backgauge finger for gauging long, small strips

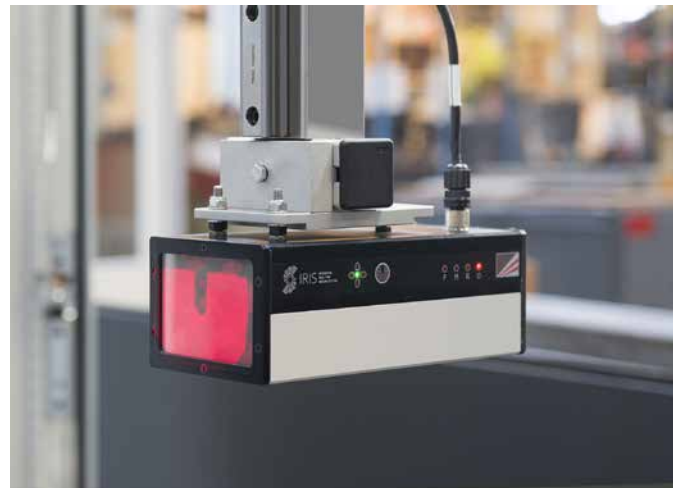

Lasersafe safety system



Special colour

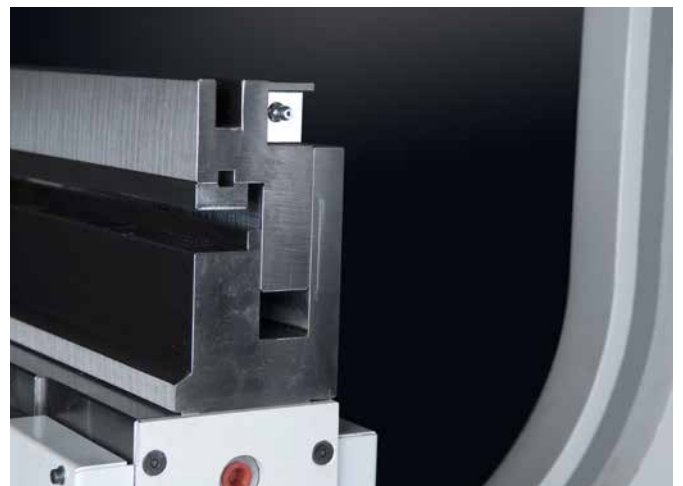

Hemming table

TECHNICAL SPECIFICATIONS

Type		50/20	80/15	80/20	80/25	80/Turbo	110/30	110/40	110/42	110/turbo	135/30	135/40
Pressing force	kN	500	800	800	800	800	1.100	1.100	1.100	1.100	1.350	1.350
Pressure	bar	290	290	290	290	290	245	245	245	245	290	290
Working length	A mm	2.000	1.500	2.000	2.500	-	3.050	4.000	4.270	-	3.050	4.000
Dist. betw. uprights	B mm	1.550	1.050	1.550	2.050	-	2.600	3.150	3.820	-	2.600	3.150
Stroke	C mm	200	200	200	200	-	200	200	200	-	200	200
Distance table/ram	E mm	400	400	400	400	-	400	400	400	-	400	400
Gap	D mm	300	400	400	400	-	400	400	400	-	400	400
Table width	F mm	120	120	120	120	-	120	120	120	-	120	120
Max. load table	kN/m	2.000	2.000	2.000	2.000	-	2.000	2.000	2.000	-	2.000	2.000
Working height	mm	970	970	970	970	-	970	970	970	-	970	970
Approach speed*	mm/s	150	130	130	130	160	130	130	130	180	130	130
Working speed**	mm/s	17	13	13	13	22	12	12	12	22	12	12
Return speed	mm/s	190	140	140	140	200	115	115	115	200	115	115
Motor	kW	7,5	11	11	11	15	15	15	15	22	15	15
Weight	kg	5.500	5.500	6.000	6.500	-	9.500	11.000	12.000	-	9.500	11.000
Oil tank	L	180	125	125	125	125	250	250	250	-	250	250

Type		135/42	135/turbo	170/30	170/40	170/42	170/51	170/turbo	220/30	220/30 Plus	220/40	220/40 Plus
Pressing force	kN	1.350	1.350	1.700	1.700	1.700	1.700	1.700	2.200	2.200	2.200	2.200
Pressure	bar	290	290	285	285	285	285	285	285	285	285	285
Working length	A mm	4.270	-	3.050	4.000	4.270	5.100	-	3.050	3.050	4.000	4.000
Dist. betw. uprights	B mm	3.820	-	2.600	3.150	3.820	4.550	-	2.600	2.600	3.150	3.150
Stroke	C mm	200	-	200	200	200	200	-	200	300	200	300
Distance table/ram	E mm	400	-	400	400	400	400	-	400	570	400	570
Gap	D mm	400	-	400	400	400	400	-	400	400	400	400
Table width	F mm	120	-	120	120	120	120	-	120	200	120	200
Max. load table	kN/m	2.000	-	2.000	2.000	2.000	2.000	-	2.000	2.500	2.000	2.500
Working height	mm	970	-	970	970	970	1.020	-	970	1.000	970	1.000
Approach speed*	mm/s	130	180	130	130	130	130	180	120	120	120	120
Working speed**	mm/s	12	22	15	15	15	15	22	21	21	21	21
Return speed	mm/s	115	200	160	160	160	160	200	200	200	200	200
Motor	kW	15	22	22	22	22	22	37	37	37	37	37
Weight	kg	12.000	-	11.000	13.000	14.500	19.500	-	12.500	13.000	15.000	15.500
Oil tank	L	250	250	350	350	350	350	-	350	350	350	350

* For CE-countries only if the machine is equipped with an optional safety system. ** For CE-countries working speed is limited to safety norm.
 Different combinations of stroke and daylight are available in our standard range by steps of +100 mm.
 Specifications subject to change without prior notice.

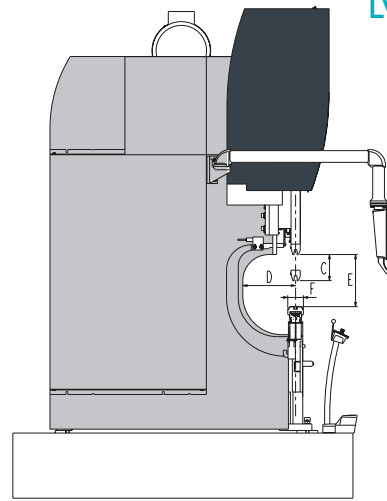
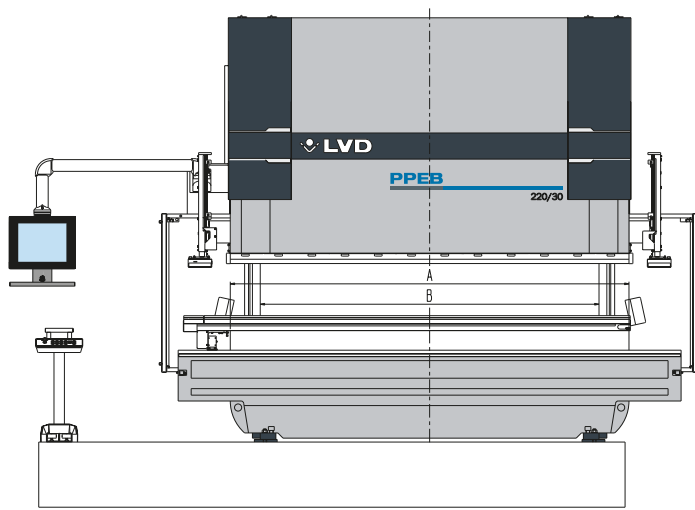

Type		220/42	220/42 Plus	220/51	220/51 Plus	220/61	220/61 Plus	320/30	320/40	320/45	320/51	320/61
Pressing force	kN	2.200	2.200	2.200	2.200	2.200	2.200	3.200	3.200	3.200	3.200	3.200
Pressure	bar	285	285	285	285	285	285	285	285	285	285	285
Working length	A mm	4.270	4.270	5.100	5.100	6.100	6.100	3.050	4.000	4.500	5.100	6.100
Dist. betw. uprights	B mm	3.820	3.820	4.550	4.550	5.050	5.050	2.600	3.150	3.820	4.270	5.050
Stroke	C mm	200	300	200	300	200	300	300	300	300	300	300
Distance table/ram	E mm	400	570	400	570	400	570	570	570	570	570	570
Gap	D mm	400	400	400	400	400	400	400	400	400	400	400
Table width	F mm	120	200	120	200	120	200	200	200	200	200	200
Max. load table	kN/m	2.000	2.500	2.000	2.500	2.000	2.500	2.500	2.500	2.500	2.500	2.500
Working height	mm	970	1.000	1.025	1.055	1.025	1.055	1.000	1.000	1.000	1.035	1.165
Approach speed*	mm/s	120	120	120	120	120	120	120	120	120	120	120
Working speed**	mm/s	21	21	21	21	21	21	14	14	14	14	14
Return speed	mm/s	200	200	200	200	200	200	130	130	130	130	130
Motor	kW	37	37	37	37	37	37	37	37	37	37	37
Weight	kg	16.500	17.000	20.500	21.000	23.500	24.000	21.000	23.000	25.500	29.000	36.000
Oil tank	L	350	350	350	350	350	350	400	400	400	400	400

Type		400/40	400/45	400/51	400/61	500/40	500/45	500/51	500/61	640/45	640/61	640/81
Pressing force	kN	4.000	4.000	4.000	4.000	5.000	5.000	5.000	5.000	6.400	6.400	6.400
Pressure	bar	290	290	290	290	290	290	290	290	290	290	290
Working length	A mm	4.000	4.500	5.100	6.100	4.000	4.500	5.100	6.100	4.500	6.100	8.100
Dist. betw. uprights	B mm	3.150	3.820	4.270	5.050	3.150	3.760	4.050	5.050	3.760	5.050	7.050
Stroke	C mm	300	300	300	300	300	300	300	300	300	300	300
Distance table/ram	E mm	570	570	570	570	570	570	570	570	570	570	570
Gap	D mm	400	400	400	400	400	400	400	400	400	400	400
Table width	F mm	200	200	200	200	200	200	200	200	200	200	200
Max. load table	kN/m	2.500	2.500	2.500	2.500	2.500	2.500	2.500	2.500	2.500	2.500	2.500
Working height	mm	970	970	970	970	970	970	970	970	970	970	970
Approach speed*	mm/s	100	100	100	100	100	100	100	100	90	90	90
Working speed**	mm/s	11	11	11	11	9	9	9	9	9	9	9
Return speed	mm/s	120	120	120	120	80	80	80	80	100	100	100
Motor	kW	37	37	37	37	37	37	37	37	55	55	55
Weight	kg	30.500	32.000	34.000	37.000	39.400	42.200	43.820	49.420	49.300	57.000	71.550
Oil tank	L	500	500	500	500	650	650	650	650	850	850	850

SOFTWARE INTEGRATION

LVD's database-driven CADMAN® suite software integrates sheet metalworking processes, production control, communication and management. It provides users real-time data to make informed choices, enabling optimised programming and maximised throughput in the workshop.

CADMAN-JOB

CADMAN-JOB connects the front office intakes and processing of orders with the shop floor operations. The software creates or imports production orders from an ERP system allowing users to generate production jobs for bending.



CADMAN-B

After importing a 3D CAD part, CADMAN-B automatically defines inclined, parallel and multi-bends, as well as hemming and preliminary bends. The module can visualise the complete bend process with start to finish collision detection, gauge positions and tool setups.

Touch-B control

The speed and simplicity of touch screen technology is combined with the power of a CNC control. Touch-B works with the centralised CADMAN database, is compatible with CADMAN-JOB and CADMAN-B and has access to LVD's customer support helpdesk.

Touch-i4

Touch-i4 is an industrial-grade Windows®-based tablet that provides an overview of the entire fabrication workshop. It collects real-time information from your LVD machine(s) powered by the centralised CADMAN database.

CADMAN-SDI

The Smart Drawing Importer allows fast CAD file import. CADMAN-SDI converts the file to OSM and stores it in the central datase. All cost drivers are displayed and can be exported for making an accurate cost estimate.

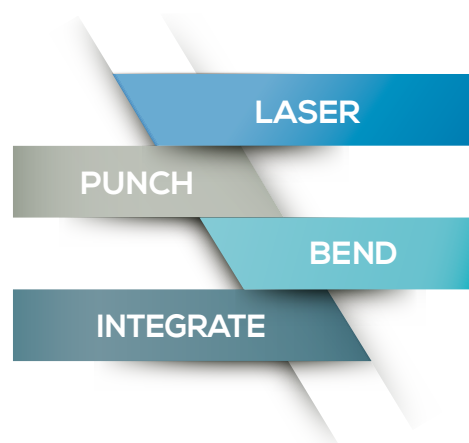

LVD Company nv, Nijverheidslaan 2, B-8560 GULLEGEM, BELGIUM
Tel. +32 56 43 05 11 - marketing@lvd.be - www.lvdgroup.com

For full address details of your local subsidiary or agent, please visit our website.

